

# Simulation of Super Capacitor Voltage-Decay Behavior

Aditya S. Sengupta\* & G Raam Dheep

aditya.nitagt@gmail.com

Assistant Prof, Lovely Professional University, Phagwara, Punjab, India

**Abstract**—The Ultra Capacitor finds its application in lot of industrial applications. The super-capacitor (SC) behavior is used in a number of innovative applications. This paper deals with a circuit that uses battery and power electronics components to mimic the super-capacitor discharge behavior. That can be used to operate a (constant 5volt) d.c- d.c boost converter. This paper also report the creation of a new ultra capacitor voltage decay structure with the help of power electronics components. By this new ultra-capacitor voltage decay circuit we can use it low voltage battery charging and other different voltage level application.

**Keywords**— large-value capacitor, pulse, modulation, PWM.

## (I) SUPER-CAPACITOR PRINCIPLE

Ultra Capacitor (UC) or super-capacitor has been known as electrochemical double layer capacitor. This UC is the device that stores so much energy that it can carry 100x more power than usual batteries. Super-capacitor (SC) can store more energy [1], than conventional capacitors [2]. This high storage-capability is attained by increasing electrodes surface area of the SC. SC stores very high energy and can quickly deliver the power [3] as needed. Eg: during vehicle acceleration SC would supply the required high current and power [4] and increase efficiency. Like conventional capacitor a double layer capacitor consist of two metallic plates separated by an separator, the separator is permeable as ions can move through it to the electrodes [1]. The large surface area of the SC is an advantageous feature as ions get attached tightly to the electrode's inner surface although distance between the positive and negative electrodes is in of nanometers range. Scientists are carrying out research to make mega-farad SCs [5]. Researchers are developing dc dc converter circuit powered by only SCs [6]. Also hardware verifications have also been done by researchers [7] regarding development of supercapacitor powering dc-dc converter and also trying to implement the same in consumer electronics [8].

The idea that is introduced and described in the following sections is that here we are designed a circuit that would give out voltage looking like discharging SC voltage by using a d.c to d.c converter (buck converter) and finally we are getting the output of the super-capacitor or the long duration voltage decay of SC by which this circuit will store the charge for very long duration or the discharging time of the circuit is near about 4 to 5 hours. By using this long duration voltage decay we can use this circuit for low voltage application like battery charging. Though the super-capacitor cost is very high, by implementing this circuit we can use it on behalf of super-capacitor and thus the cost will reduce. By reducing the cost we could use it in hybrid vehicles and that hybrid vehicles cost would reduce too.

## (II) SUPER-CAPACITOR PRINCIPLE

The basic principle governing SC is same like conventional capacitors however SC has higher surface area along with dielectrics which reduce the distance  $D$  between electrodes. So, this two effect increases the capacitance and the energy storage capability of a super-capacitor. However by enabling the low equivalent series resistance (ESR) value of normal capacitor, ultra-capacitor can obtain similar power

density. The capacitance of SC can be calculated and estimated by ‘Helmholtz double-layer formation’. The particular capacitance is given by (1).

$$C = \epsilon_0 \epsilon_r \frac{A}{d} \tag{1}$$

In (1) C symbolizes capacitance,  $\epsilon_0$  resembles dielectric-constant of free-space,  $\epsilon_r$  stands for relative dielectric constant of the medium between the two layers, A is the surface area, and D is the distance between the layers. Like conventional capacitor, the stored energy of a SC can be calculated by (2).

$$E = \frac{1}{2} CV^2 \tag{2}$$

In equation (2) ‘V’ is the SC voltage and E is the energy stored in the SC.

### (III) WHY WE GO FOR CIRCUIT TO GENERATE VOLTAGE DISCHARGE OF SC

Here we have simulated voltage-decay behavior of the SC. By using this circuit cost will reduce. Now this circuit is a developing stage of super-capacitor. Here from this equivalent circuit we can tell that how much farad super-capacitor is needed for that particular application. SC is very costly to procure so, it is one reason to developing this circuit. From this circuit no possibility of electrical hazard but if we use super-capacitor in laboratory electrical hazard may occur, another one is super-capacitor size is big comparatively conventional capacitor. From the output voltage of this equivalent circuit we will get different kind of voltage level which is applicable in different application, like battery charging, hybrid vehicles, UPS system etc.

### (IV) EQUIVALENT-CIRCUIT OF THE VOLTAGE-DISCHARGE OF SC

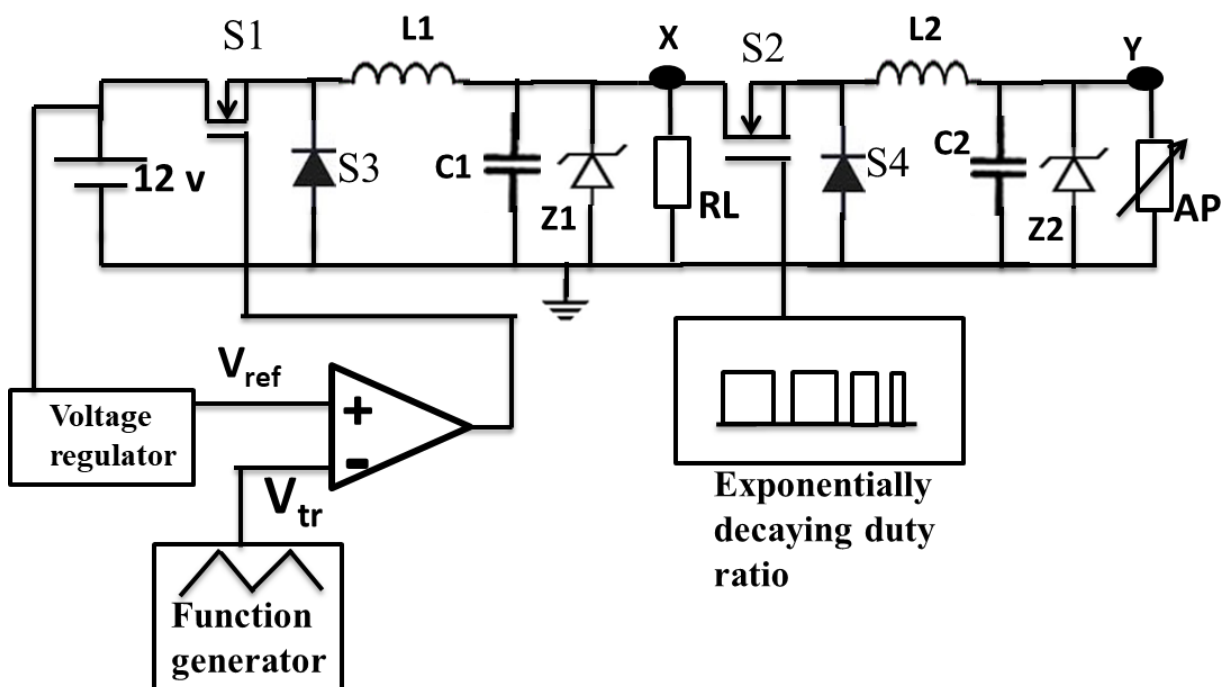

Fig1: Equivalent Circuitry Of Voltage-Decay Of SC

The circuit diagram shown in fig 1 is a two stage buck circuit. In this figure ‘L1’ and ‘L2’ are inductances, ‘C1’ and ‘C2’ are capacitances, ‘Z1’ and ‘Z2’ are zener diodes, ‘RL’ will be a very high load while ‘AP’ is the application running on the voltage at ‘Y’. ‘S2’ and ‘S1’ are MOSFETS.

Here in this circuit diagram we have taken a d.c source voltage which fed the d.c to d.c (buck converter) converter as its input. From the first stage of this buck converter ending at 'X' we will get the 2.85 volt d.c which will be constant. From this 2.85 volt constant d.c source voltage which is applied as a input voltage to the second stage of d.c to d.c buck converter starting from point 'X', for triggering this buck converter we use switching pulse of exponentially decaying duty ratio that operates 'S2'. This switching pulse of exponentially decaying duty ratio together with the fixed 2.85 V will give out an exponentially decaying voltage following the decay curve of the duty ratio operating 'S2'. The exponentially decaying duty ratio switching pulse has been generated by arduino,

(V) SIMULATION RESULT.

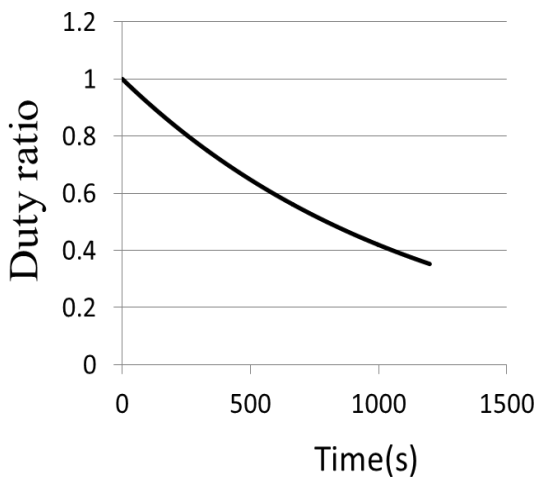

Fig. 2. Exponentially decaying duty ratio

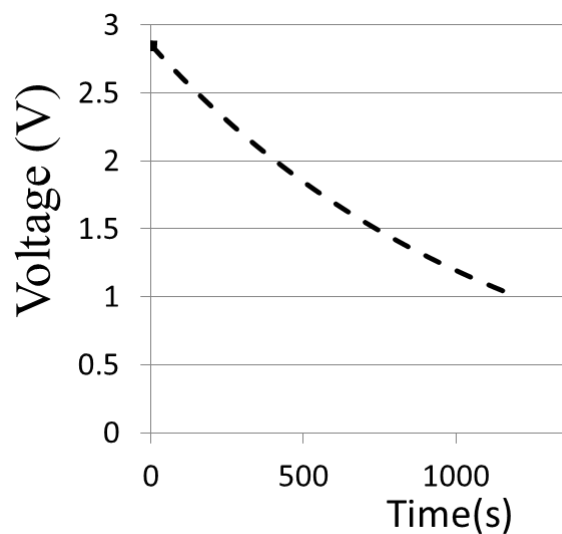

Fig. 3. Mimicked SC discharge behavior

The application 'AP' is drawing constant power at 5V and 2A. In this fig 2 the duty cycle is given which is observed to be decaying exponentially. Time and this duty ratio is operating switch 'S2'. Fig.3 shows the discharge behavior of SC modelled by the equivalent circuit.

(VI) CONCLUSION

The proposed model is capable of simulating the voltage decaying behavior of an SC .This model is capable of predicting the super-capacitor voltage decaying behavior. By simulating this circuit of the ultra-capacitor we can tell that for the particular application how much Farad super-capacitor is required. Basically we are mimicking the Maxwell 2.85 volt, 3000F UC voltage decay behavior. From this output voltage of this circuit we will get different kind of voltage level which is applicable in different application like battery charging, hybrid vehicles etc. In simulation result we got some ripple in voltage waveform, further we will try to decrease the ripple voltage in the simulation. This circuit will help us to determine what kind of SC we need to buy or to do research on for a given applications where we require only super-capacitor and no additional power supplies or batteries are available. Very easily we can handle this circuit in laboratory. From this circuit we can get different kind of output voltage and the time that we need those components to run in a given electronic gadgets.

## REFERENCES

- [1] A. Rufer, "A Supercapacitor Based Energy Storage System for Elevators With Soft Commutated Interface" *IEEE Trans. Ultrason Ferroelectr Freq Control*, vol.38 ED-5, pp.1151-1159, September 2002.
- [2] R. Chen, Y. Liu, F. Z. Peng "A Solid State Variable Capacitor With Minimum Capacitor" *IEEE Trans Power Electron*, vol.32 ED-7, pp.5035-5044, July 2017.
- [3] S. K. Kollimalla, M. K. Mishra, N. L. Narasamma "Design and Analysis of Novel Control Strategy for Battery and Supercapacitor Storage System" *IEEE Trans. SUSTAIN ENERG*, vol.5 ED-4, pp.1137-1144, Oct 2014.
- [4] E. G. Bakhoun, "New mega-farad Ultra-Capacitor" *IEEE Trans. Ultrason Ferroelectr Freq Control*, vol.56 ED-11, pp.14-21 January 2009.
- [5] M. B. Camara, H. Gualous, F. Gustin, A. Berthon, "Design and New Control of DC/DC Converters to Share Energy Between Supercapacitors and Batteries in Hybrid Vehicles" *IEEE Trans Veh Technol*, vol.57 ED-5, pp.2721-2739, September 2008.
- [6] A. S. Sengupta, S. P. Mohanty, B. K. Bhattacharyya, "DC–DC Buck Converter Solely Powered By Supercapacitors For Efficiently Powering The Hand-Held Devices," *IET Power Electron.*, vol.11 ED-12, pp. 1946 - 1954, Oct. 2018.
- [7] A. S. Sengupta, S. Satpathy, S. P. Mohanty, D. Baral, and B. K. Bhattacharyya, "Supercapacitors Outperform Battery," *IEEE Consumer Electron. Mag.*, vol.11 ED-12, pp. 50-53, Sep. 2018.
- [8] A. S. Sengupta, A. K. Chakraborty, B. K. Bhattacharyya, "Supercapacitor Module Solely Powering DC–DC Buck Converter for Hand-Held Applications," *IETE J. Res.*, <https://doi.org/10.1080/03772063.2018.1466733>.