

Design and Fabrication of Bomb Disposal Robot

Himanshu Arora*¹, P. N. S. Vivek², Puneet Sharma^{#1}, Varun Panwar¹, P. G. Arora³

¹Assistant Professor, Mechanical Engineering, Lovely Professional University, Phagwara, India

²UG Student, Mechanical Engineering, Lovely Professional University, Phagwara, India

³Assistant Professor, Electronics and Communication Engineering, Lovely Professional University, Phagwara, India.

Main Author - *himanshu.18602@lpu.co.in, Corresponding Author - #puneet.16925@lpu.co.in

ABSTRACT

In many applications, it is sometimes not enviable for people to actually go to a certain locations such as discovering and disseminating explosive substance, keep under surveillance a place or spotting a land mine. Improvements in robotic technology have enabled automated and unmanned machines to carry out activities earlier only feasible by wearing a bomb suit for trained personnel. A war field robot is being developed in this work that is capable of crossing land surfaces, collecting and destroying different stocks of explosives and providing enhanced recognition abilities for law enforcement and military agencies. The core interest behind the proposed design is to provide a line of defence against the existing threatening risk to a bomb disposal squad. The proposed robotic system can be steered in various directions with the help of a remote controller unit wirelessly, which receive command from an individual and execute reliable movements on the basis of these inputs. Here, Arduino is the controlling division of the intact arrangement due to which the circuit intricacy is improved and operation speed is amplified. The complete robotic system is composed of a manipulator, an end-effector, a moving base, and camera as a sensor for visual inputs. For the movement of the joints, links and end-effector of the robotic arm, DC and Stepper motors are used, which work using the relays and, further controlled with the help of remote via radio-frequency element. Thus, squad can secure space to destroy off a bomb, that they generally to do in a close proximity. A LCD is provided in a remote controller unit that gets video signals from the visual sensor. Foremost characteristics of this robotic system comprised of a spontaneous customer interface with additional sensor feedback and enhanced perceptible understanding in comparison to the prevailing systems. Along with this, an on-board manipulator arm providing wider workspace, and a dexterous gripper to deal with the shell. With the help of this robot, it is easy to assess a safe range from the danger, thus the efficiency of squads will upgrade. Also, the other various factors like less-expenditure; unprompted action and ease-of-maintenance prop up its extensive reach, by this means saving the lives of people.

INTRODUCTION

It is known that a range of inventions have been effectively completed in the ground of robotics in the form of serial robot, parallel robot, planar robot, miniature robot, human shaped robot, etc. as the drift of the engineering is shifting from the existing form of mechanization to unmanned machines. Human beings have been the main motivation to develop the robot system for many years. With the robotic research which has been conducted so far, it certainly had many challenges and limitations. Numerous efforts have been made to build up robots to substitute people with tasks such as shell disposing, which are quite critical and risky for human life. Hundreds of skilled workers are injured or lose their lives during the disincentive of bombs

every day. The numerous news articles distributed regularly in the world's newspapers are available for review of this situation. The fundamental plan is to offer a robot for shell dissemination along with straightforward responsibilities like cutting wires, flip on switches, pick and drop light weight things, etc. and a simple autonomous robot to assist in the transfer and dissemination of the shell, which can be operated at a distance by a squad personnel. This robotic system works on computer command and order based. Instructions are taken from the client in the structure of control signals and act upon the mandatory accomplishment. The practical development of superior control algorithms along with the contribution of highly efficient controllers has resulted in quicker, more precise and more intellectual robotic device [1].

Mainly, Bluetooth unit is used a major communication system with the robotic device, which allows sharing of information amid two devices taking into account the distance the same. HC-05 is used as Bluetooth unit which is linked with the core controller and the information to the various peripheral devices will be passed via android platform. This robotic system also consists of night vision camera and interfaced with the video feedback system for effective monitoring and handling of the hazardous objects. The remote controlled robotic base and 6 degree of freedom manipulator robotic arm along with the gripper type end-effector provides dexterity to the system so as to conduct any of the bombs diffusing operation in a smooth manner. This base and arm are moved using stepper and DC motors as actuators, controlled through the Arduino via L298N motor driver IC based on the input about the directions from the user through remote control unit. The transmitting module consists of the LCD display for monitoring the camera feedback and touch screen direction buttons which transfer the instructions to the receiver unit for operating the motion of robot in different directions. The feed instruction is primarily manipulated at the transmitter action unit, and then passed via RF link in serial form, which get inward bound in core controller and manipulated another time. Outcome of this controller unit is the certain information about motion and other operation to the suitable component such as the motors of the robotic base or the manipulator arm or the end-effector [2].

LITERATURE SURVEY

1. HC-05 Bluetooth Module: The easy-to-use Bluetooth module is designed for the configuration of transparent serial wireless connections, which can be utilized in a Master or Slave setup. This Bluetooth Serial port is entirely competent with a 2.4GHz transceiver and base band Bluetooth V2.0 + EDR (Enhanced data rate) 3Mbps Modulation. This uses the Bluecore 04-External Bluetooth single chip CSR module with CMOS technology and the AFH system [3].

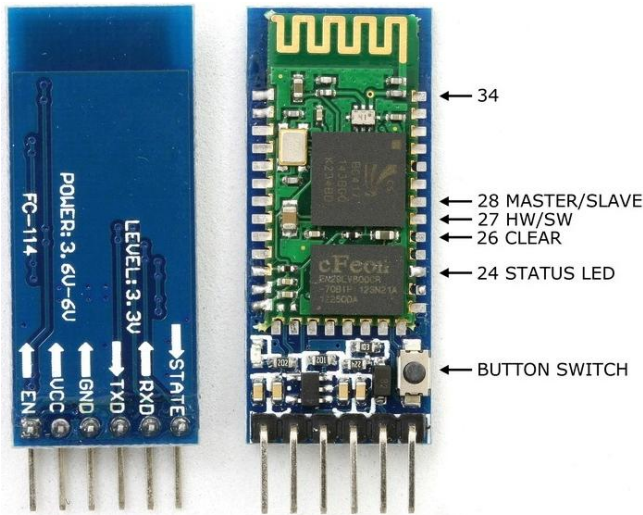

Figure1: Bluetooth Module HC-05

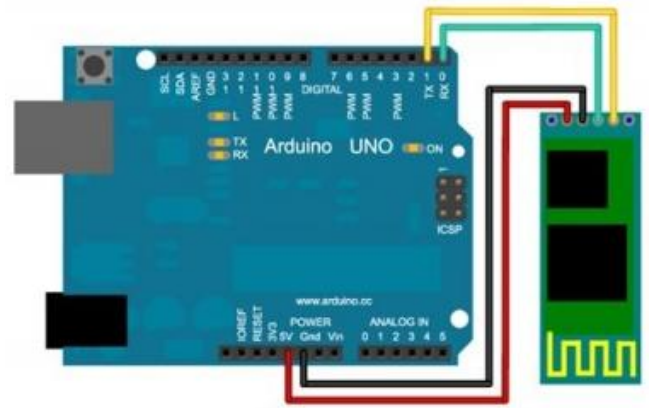

Figure2:Arduino

2. Motor Driver L298N: It is a unit for connecting motors which allows controlling the running speed and direction of four motors simultaneously. L298N dual H-bridge driver is the most commonly used driver for Bidirectional motor driving applications. With L298N Motor Driver IC, that task is made simple and has helped in a number of applications with relative ease. L298N is a 15 Pin Motor Driver IC. This is designed to provide bidirectional drive currents at voltages from 5 V to 36 V. The L298N can drive small and quiet big motors as well. This motor driver IC can simultaneously control four small motors in either direction; forward and reverse with just 4 microcontroller pins [4].



Figure3: L298 Motor Driver

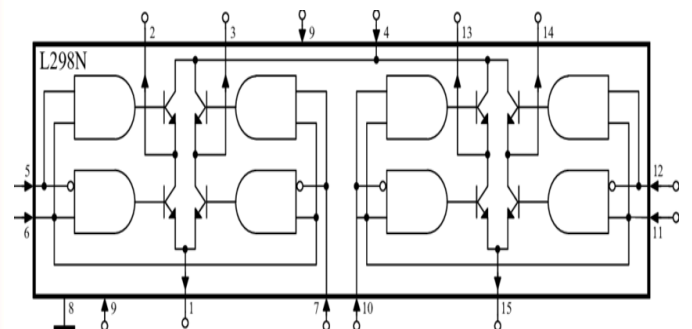

Figure4: Dual H-Bridge Circuit

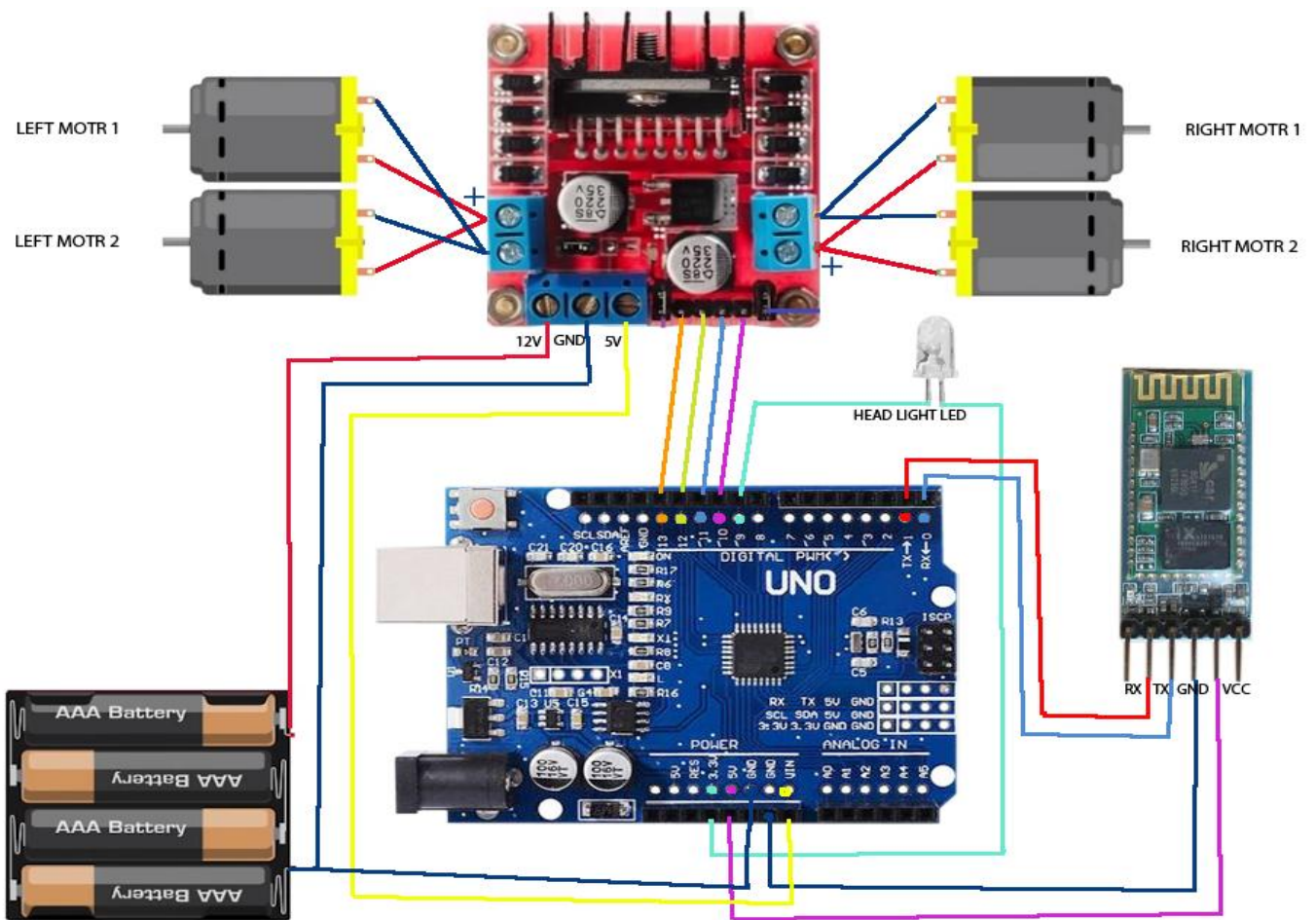

Figure5: Motor Driver Circuit with Bluetooth Module

3. **Arduino:** It is the MicrochipATmega328P Microcontroller's open-sourced board and developed by Arduino.cc. The panel has a set of input / output (I / O) digital and analog pins which can be attached to several boards (shielding) and other circuits. The panel has 14 virtual I / O pins (six PWM output-capable), 6 analog I / O pins and is programmable using an Arduino IDE via a USB cable of type B. The USB cable or an external 9 volt battery can be supplied, but it accepts voltages of between 7 and 20 volts [5].

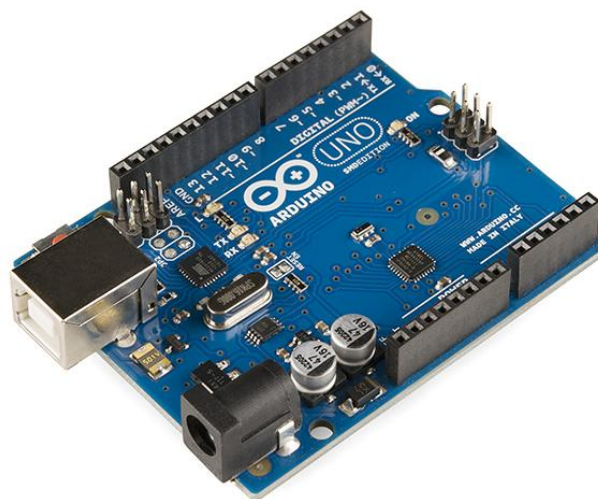

Figure6:Arduino

4. DC Motor: There are four 12V DC motor which are used for driving the robot. The motor are attached to each of the wheel of the robot base. The power from the motors is given to the robot base so as to drive and steer the robot with ease. The motion and its capabilities are dependent on the function that is coded on to the micro controller which is executed of the signal command from the application [6]. The DC actuators are connected by pins 4 and 5 via the L298N IC and other actuators by pins 6 and 7.



Figure7: DC MOTOR

5. Servo Motor MG 966: It is a rotary actuator or linear actuator that precisely controls angular or linear position, direction and rate. It consists of a suitable motor coupled to a sensor for position feedback. **The MG996R is a metal gear servo motor with a maximum stall torque of 11 kg/cm.** Like other RC servos the motor rotates from 0 to 180 degree based on the duty cycle of the PWM wave supplied to its signal pin. To make this motor rotate, power the motor with +5V using the Red and Brown wire and send RX, TX signals to the Orange colour wire via Bluetooth application. The servomotors are used in 6 DOF robotic arm the signal pins are connected to Arduino mega communication RX, TX from 14 to 19 pins [7].



Figure8: Servo Motor



Figure9: 6 DOF Robotic Arm

6. Wireless Camera: A wireless video camera is used to promote night vision and better monitoring, the camera module supports a video transmitter as well and the receiver module is interfaced with the control module using a LCD display and the live video feedback from this camera is received by tuning the receiver to the particular frequency and the LCD is connected to the receiver module from the AV port in the receiver and thus live feedback can be viewed by the bomb disposal expert in the LCD

display. In an FPV system the video image from an on board camera is transmitted by radio to a personal video display on the ground in the form of a screen or video goggles. The camera is directly powered by 9V 2A from regulatory circuit. The camera has its own radio frequency transmitting and receiving signals [8].



Figure10:Wireless Camera

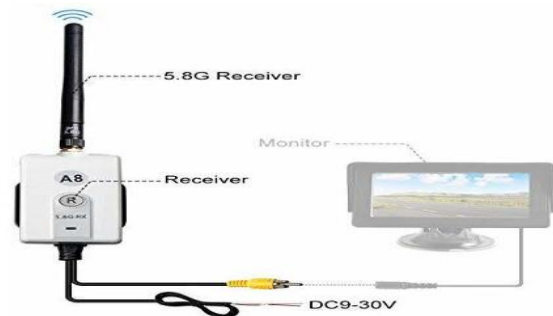

Figure11: Camera Receiver with LCD Display

7. Metal Detector: The metal detector is used for the identification of small objects in metal; the coil of the device is used to detect near the target. The input of the circuit will be colpitt's RF range oscillator which will have a sensing coil as part of tuned oscillator. The metal detector mainly uses a digital transmitter and receiver. When our search coil passes through the metal then the digital signals of certain amplitude breaks through the peak detector. Since these are ion audio range they are sent to the headphones.

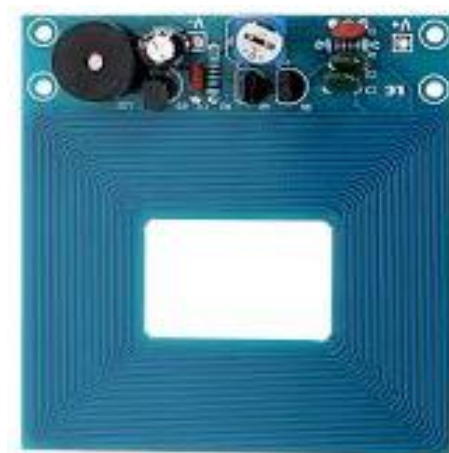

Figure12: Metal Detector

BLOCK DIAGRAM

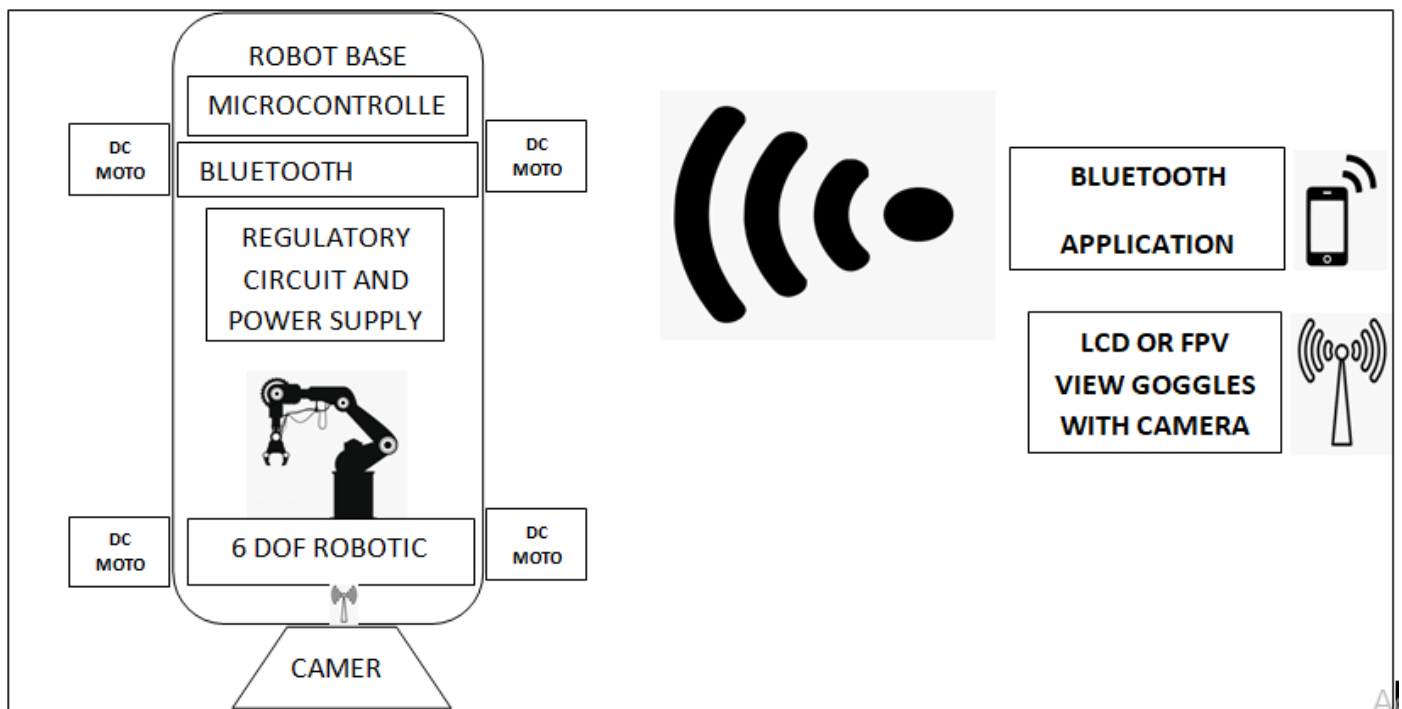

Figure 13: Overall System Architecture

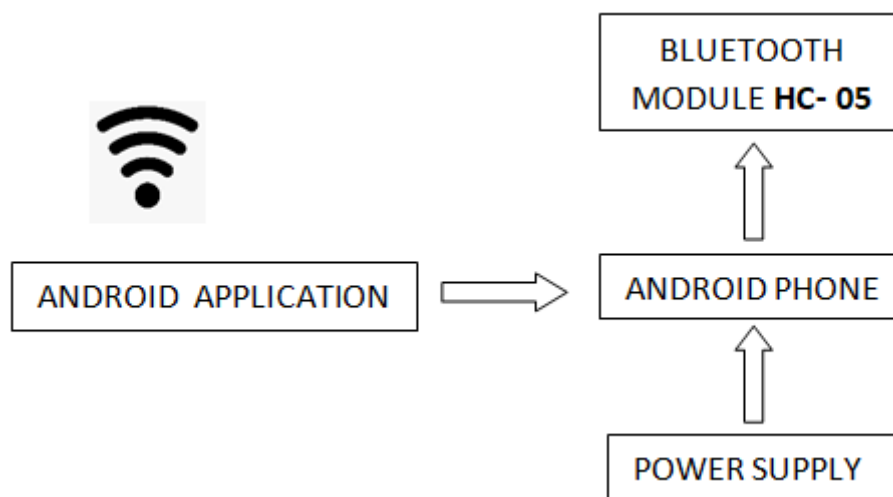

Figure 14: Transmitter Architecture

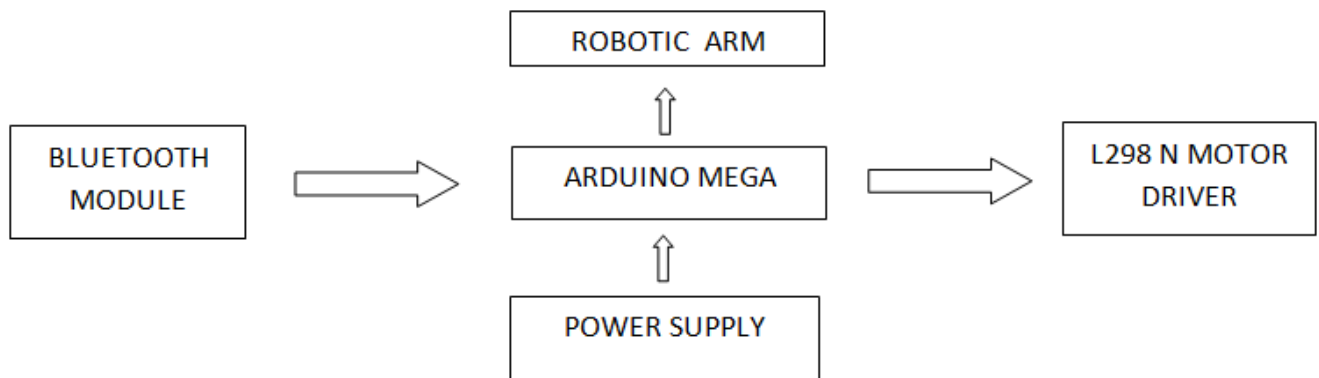

Figure 15: Receiver Architecture

CIRCUIT DIAGRAM

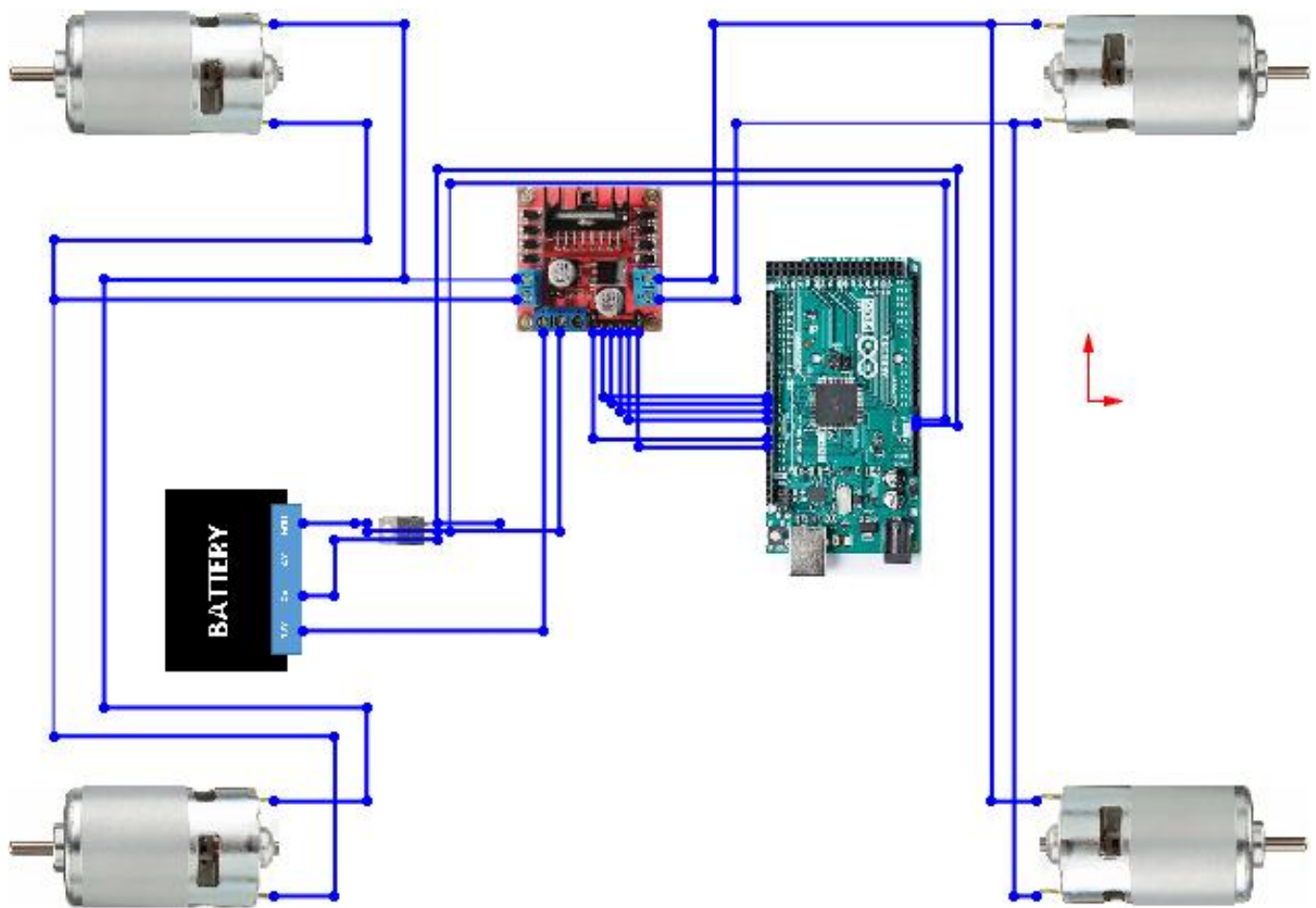

Figure 16: Arduino Interfacing with Motor Driver (L298N)

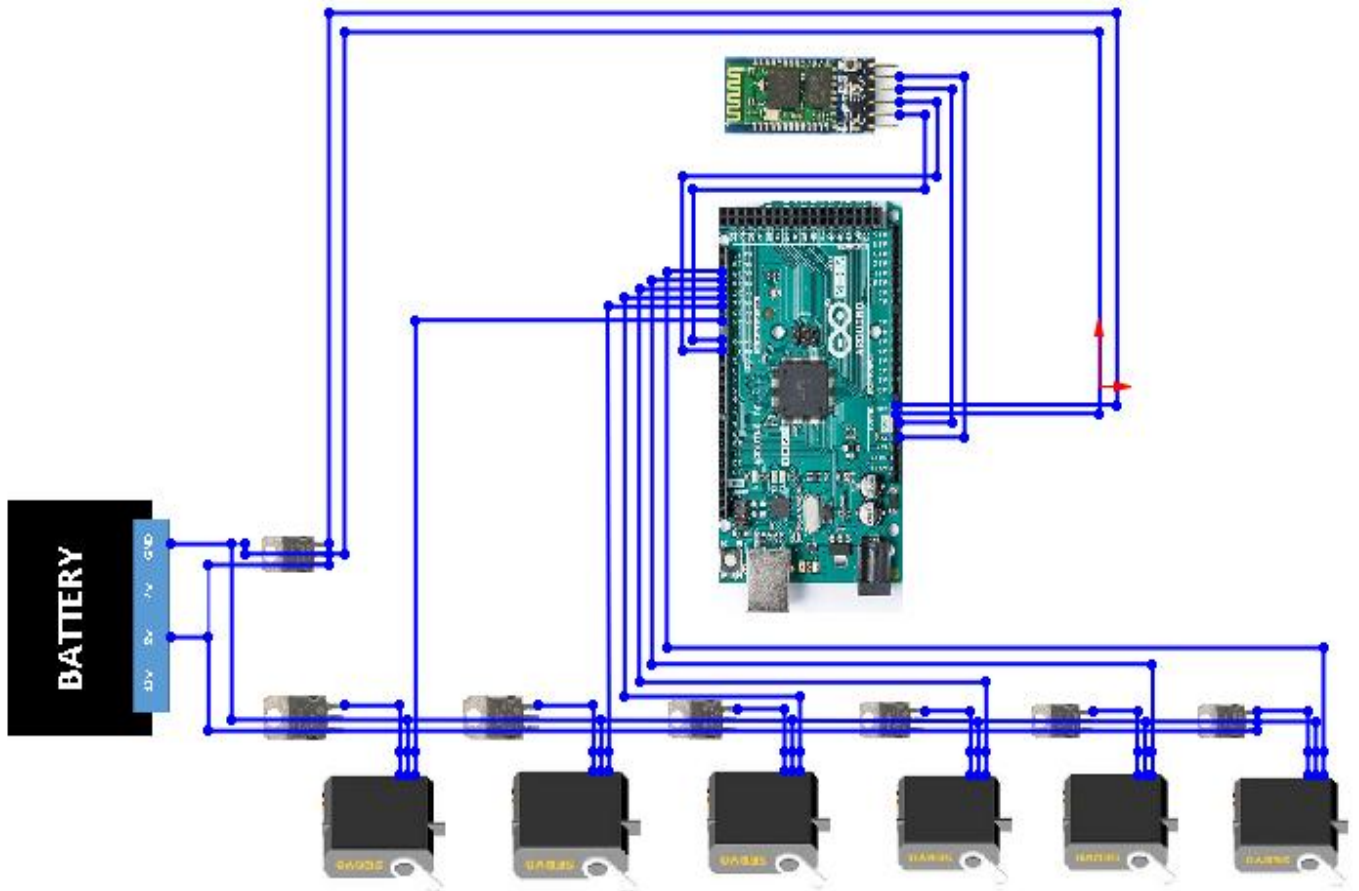

Figure 17: Arduino Interfacing with Bluetooth Module and Servo Motors

REAL TIME DESIGNED PROJECT STRUCTURE

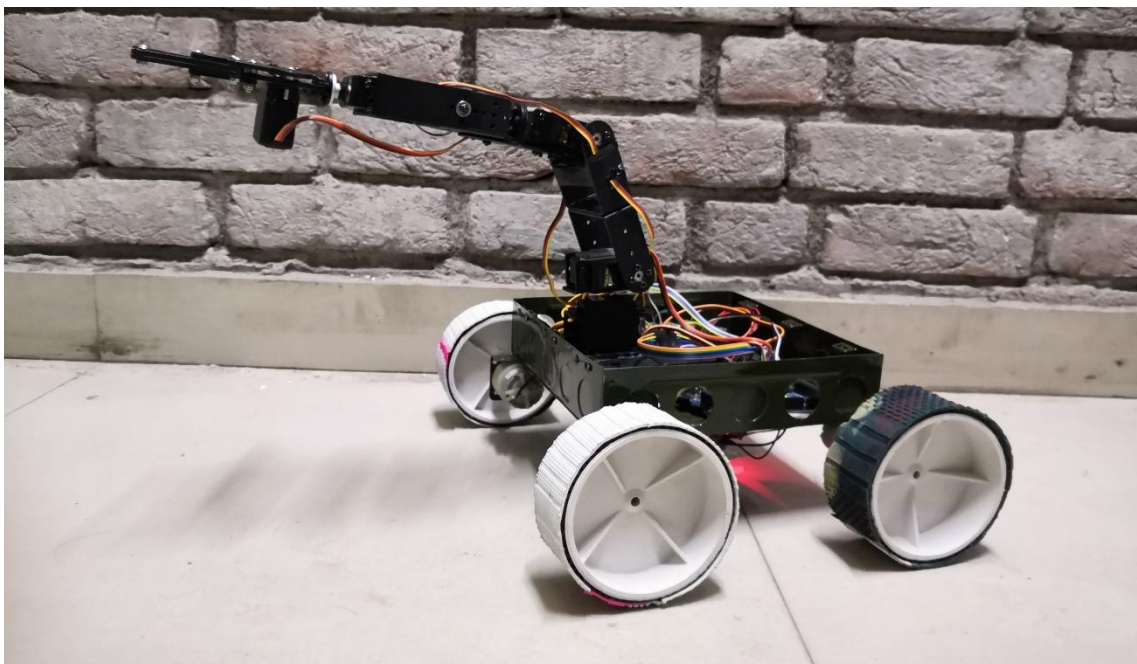

Figure 18: Real Time Fabricated Automated BOT

TESTING

- A. Test based on Integration:** After checking the robot individually, the robot goes through integration test. Every circuit connected to the micro controller and are test through serially. Signal prepared by the application through the serial port on the micro controller are checked by the turning ON& OFF of the motors.
- B. Test based on Validation:** The checking by validation needed by the signal generated through the application is tested. The Testing is completed when the right amount of motor movement is observed by required signal is generated.

CONCLUSION

The Wireless Bomb Disposal Robot was designed to meet the needs of the bomb disposal unit, the Army, the police and the staff handling radioactive materials. This will assist to reform discriminating shield of nation from rebellions and terrorists. The prime focus of this work is achieved as the designed system is very accurate and precise in working and cost-effective. With such technology, squads can discover the barrage as early as possible and take to pieces in quite relaxed mode so that the life of the human beings can be saved easily. It detects the signal which is transmitted and according to that control robot in forward, backward, left turn, right turn movements. It also allows users to view the things accurately that are currently happening in the surrounding area. Taking in to account the complexity of earlier circuits, the circuit designed for this is straightforward. Now, this design system can be utilized in numerous applications in harsh environments and scenarios. For illustration, it can be used by the squad personnel, and also for dealing with mines. Moreover, some applications could be related to spying in hostage circumstances.

REFERENCES

1. Keerthana, S., A. R. Vellaiyan, and M. Rajamohan. "Bomb detection and disposal robot: Aid for risky Military Fields."
2. Uphad, Rushikesh, et al. "A SECURE BOMB DIFFUSAL SPY ROBOT CONTROLLED USING ANDROID APP." (2019).
3. Vidyashree, H., et al. "All Terrain Robotic Vehicle With Robotic Arm For Dangerous Object Disposal." *International Journal of Advanced Research in Computer Science* 9.5 (2018).
4. Parmar, Richa, et al. "Military Spying & Bomb Diffusing Robot with Night vision." (2017).
5. Matta, Vijay, et al. "Wireless Pick and Place Robotic Arm Vehicle Using Arduino." *National Conference on Advances in Engineering and Applied Science (NCAEAS)*. 2018.
6. KUMAR, Mr R. VINOTH. "DESIGN AND REALIZATION OF LABVIEW BASED MONITORING AND CONTROL OF MILITARY SURVEILLANCE BOT." *network* 6 (2019)

7. Odeh, Ahmad, et al. "Bomb Defusing Electronic Robot." (2019).
8. Monica, M., and Kiran S. Patil. "Smart Wireless Autonomous Robot for Landmine Detection with Wireless Camera." *Small 6* (2018): 15.