

Automatic sheet cutting machine: Design and Fabrication using Geneva mechanism

Rohit Sharma¹, Kashmir Singh Ghatotra²
^{1,2}- School of Mechanical Engineering
Lovely Professional University, Phagwara, Punjab, India

Abstract

A very successful method for cutting sheets in the same and precise sizes is the development and manufacture of sheet metal cutting machine using Geneva. Geneva drive is a method for indexing, transmuting perpetual motion into alternating motion. The sheet is moved between the time intervals of cutting periods because of the intermittent motion. Then the mechanism of the crank and lever is used to cut the board. The sprocket serves as a hammer, and the cutter acts as a lever afterwards. A linking connection binds these two connections. The spring effect will return the cutter to its pristine position.

Key Words: Geneva Mechanism, Sheet Metal Cutting

1.1 Introduction

The Geneva wheel as designed with four slots. Hence the intermittent motion can be achieved in 360/4 degree of the wheel. The sheet cutter uses the crank and handle mechanism to cut the plate. The sprocket is behaving like a crank. The cutter is going to be a lever. A string (connecting link) connects this sprocket (crank) to the cutter (lever). The crank has a spinning movement that is transformed into linear motion. This linear motion is applied to the sheet cutter. Hence, the cutting operation is achieved.

According to P. Beer and E. Ferdinand. Russell Johnston Jr. says, "It is used in many counting instruments and other applications where intermittent rotary motion is required." Geneva Mechanisms can come in a variety of shapes and sizes. Increasing the number of slots in the system's driven wheel reduces the angular displacement by each rotation of the driving wheel. Geneva mechanisms are used for indexing purposes because the driver can rotate at a uniform speed in such mechanisms while the driven member or Geneva wheel is only intermittently actuated. [1]

1.2 History of Invention

The Intermittent Rotational Motion of Geneva wheel can be used to cut the *Sheet Metal* in small pieces.

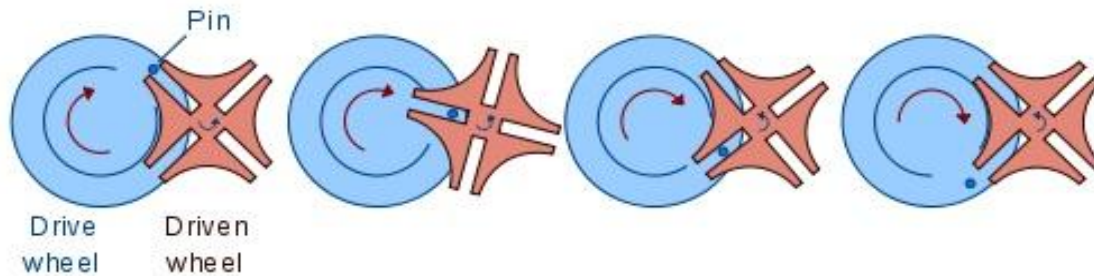

Fig. 1 Geneva Wheel Rotation

The Geneva turns constant rotational motion into periodic rotational motion. The tool, then called a Geneva Stop, can be used to limit input wheel turns when one of the slots is obstructed in the driven wheel. The Geneva has been used in this method to restrict the wind-up in springs of clockwork.

1.3 Review of Literature

Vijay et al. (2016), “*The design and analysis of sheet metal cutting machine based on Geneva mechanism*” was analyzed, they presented [3]

Georgata and Elena, “*The analysis and modeling of Geneva mechanism*” It also provides some design parameters that will specifically describe a Geneva mechanism such as number of driving cranks, number of spaces, diameter of the axle, diameter of the ball, etc. [5]

Madhoo et al., “*Force analysis of the Geneva wheel and face cam in automat*”, and He used a single motor to drive the automaton for various operations. Here they concentrate on two main parts: the Geneva wheel and the Face cam [6]

P. Kalisindhur et al. (2015), designed a mechanism for “*Cutting by giving intermittent feedthrough Geneva Mechanism*”. [7]

2. Working Principle

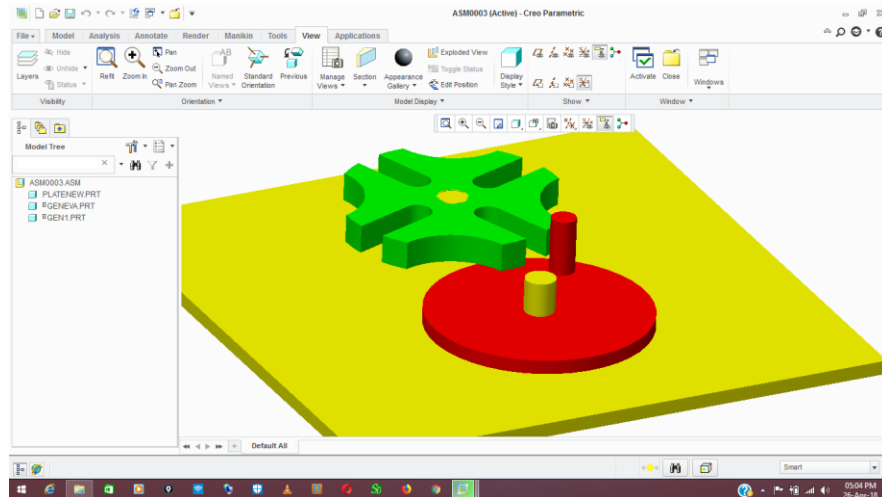

Fig. 2.Creo 2.0 Model of Geneva wheel

This project model “Fabrication of Automatic sheet cutting machine using Geneva Mechanism” was fabricated with the help of many Resources. This system is made up of many parts that are the mechanism of Geneva, engine, etc.

When the handle is rotated in counter clock wise direction, for the first half rotation. The cam pin engages the Geneva wheel. The cam pin moves from top to bottom and it rotates the roller connected with it. Hence the sheet is feed to the cutting area. The length of the sheet to be feed will be calculated by the $\frac{1}{4}$ of the circumference of the roller. The sheet feed can be adjusted by changing the roller diameter. Meanwhile the cutter will be in the open position because the crank shaft will move from right to left through bottom.

In second half rotation. The cam pin disengages the Geneva wheel. The cam pin moves from bottom to top and it will not rotate the roller fixed with Geneva. Hence there will be no sheet feeding. Meanwhile the cutter will cut the sheet because the crank shaft will move from left to right through top.

By this action of Geneva and lever in correct timing, the sheet is cut in accurate and equal dimensions. We need not to mark the sheets before cutting.

Thus the intermittent motion is achieved to get the accurate and correct dimensional sheet pieces.

3. Components and Descriptions

The main components of the model are:

3.1 Geneva wheel

In our Geneva, the drive wheel is connected to the sprocket which rotates by the roller chain. The Geneva wheel is connected to the shaft which has the sheet roller. This sheet roller is kept to feed the sheet.

The driver sprocket drives the pin to rotate in the sprocket axis. When pin meshes with the Geneva, it rotates the Geneva wheel by sliding in between the slots provided. The Geneva is the driven wheel which moves with an intermittent motion. Hence the power is transmitted to the roller with a given interval of time.

The diameter of the Geneva wheel should be same as the diameter of the sprocket wheel. Because we does not want any speed reduction or increase in speed.



Fig. 3 - Geneva wheel Drive

3.2 Sprocket



Fig. 4 – Sprocket

3.3 Roller chain



Fig. 5 - Roller Chain

3.4 Coil Spring

The spring's value is determined by the energy that it can consume. The strongest one is the spring that can consume the greatest amount of energy for the given pressure.



Fig. 6 - Coil Spring

3.5 Wear

Wearing on a roller chain has the effect of increasing the pitch (spacing the links), which allows the chain to grow longer.

$$\% = ((L - (N * P)) / (N * P)) * 100$$

L = the length of no. of links

N = the no. of links

P = Pitch

2. Machine shafts:-



Fig. 7- Machine Shaft

The Machine shaft is used in our project. The shaft is used to bear the roller, sprockets and the sheet roll.

3.6 Frame and Base

Frames are rigid structures. They maintain their shapes with or without external loads. But frame and base are main elements, because they are the main support for the machine elements.

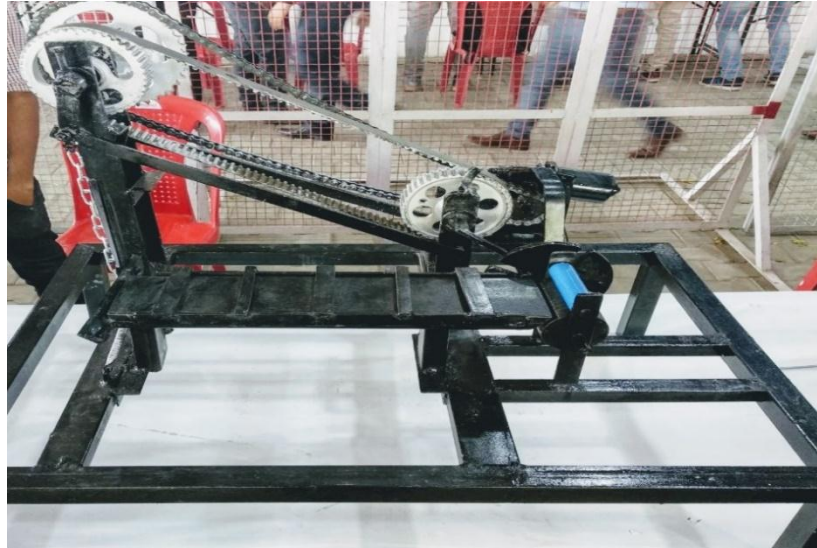

Fig. 8 - Frame Construction

In this research work, the base is taken 70 cm in length, 35 cm in width and 2 cm in thickness. The base is made up of mild steel. Hence it is rigid and bears more load on it. It can able to withstand the load produce during the working period.

3.7. Motor

The internal structure of a DC motor is designed to harness a current-carrying conductor's magnetic interaction with an external magnetic field in order to create rotational motion. The engine configuration used is 12 Volts, with 30rpm at 4.5 Amps.



Fig. 9: Motor

4. Material of Components

4.1. Material Selection

Factors to be considered during the selection of Material:

1. It must have Physical and Mechanical desired properties.
2. It can be processed or manufactured in desired shape.
3. It should provide economic solution to design problem (Relatively cheap).
4. It should be Environmental friendly.

4.2. Material of Components:-

Table 1: Material of Components

S. No	Component Names	Material	Tensile strength [N/mm ²]=MPa
1	Geneva wheel	Mild steel	860
2.	Frame and Base	Cast Iron	350
3.	Geneva Wheel	Aluminum	270
4.	Roller Chain	Alloy Steel	840
5.	Sheet Roller Shaft	Mild Steel	860
6.	Coil spring	Alloy Steel	840
7.	Sprocket	Alloy Steel	840

4.3. No. of Components

Table 2: No. of Components

S. No.	Parts	No. of
1	Geneva wheel	1
2	Sprockets	2
3	Roller chain	1
4	Sheet cutter	1
5	Sheet roller	1
6	Coil spring	2
7	Shaft	3
8	Frame and base	1

5. Design of Sheet Metal Cutting Machine

Many factors contribute to a successful Sheet Cutting machine design, by using Geneva process such as used materials, surface finishes, tolerances, loads, levels of stress, lubricants, etc. This mechanism's unsuccessful experimental implementations usually result in two failure modes: pin wear and wheel breakage. Wear is the most difficult to control of these two modes.

Components used for Projects:-

1. Geneva Wheel
2. Sprocket
3. Roller chain
4. Sheet cutter or cutting blade
5. Coil Spring

6. Sheet Roller Shaft

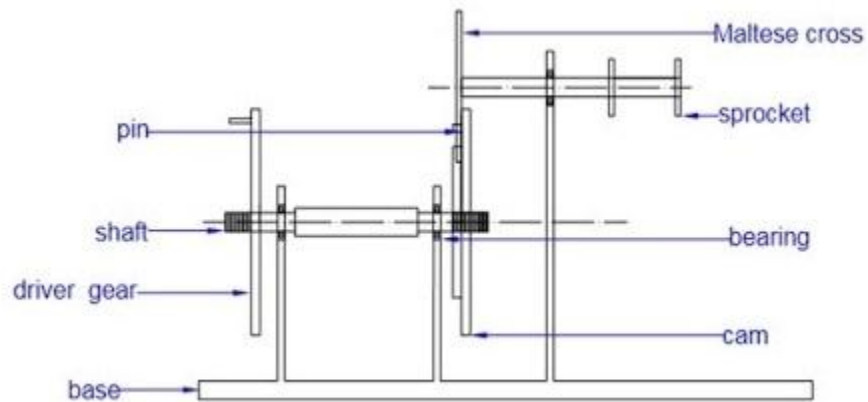

Fig.11: Line Diagram of the Project

The current design solution would minimize wear by altering the Geneva rim structure to alleviate contact pressure while retaining appropriate levels of stress in other wheel regions.

Design Calculations:--

5.1. Specification for Geneva cross

- | | |
|--------------------|-----------------------|
| 1. Slot width, | $b = 5 \text{ mm}$ |
| 2. Length of Slot, | $l = 25 \text{ mm}$ |
| 3. Shaft diameter, | $d_s = 15 \text{ mm}$ |
| 4. Thickness, | $t = 5 \text{ mm}$ |

Angular velocity of driving crank

$$\omega_1 = 2\pi N / 60 \text{ (rad/sec)}$$

Angular velocity of driven disc

$$\omega_2 = \lambda / (1 - \lambda) \omega \text{ (rad/sec)}$$

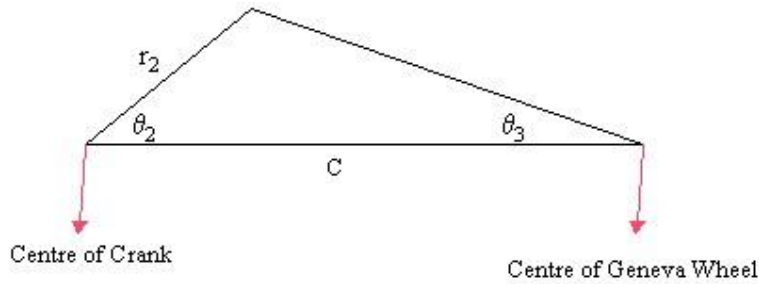

Fig. 12: Position of Geneva Wheel

The position is given by,

$$\tan \theta_3 = \frac{\sin \theta_2}{\frac{c}{r_2} - \cos \theta_2}$$

Differentiating,

$$\omega_3 = \omega_2 \frac{\frac{c}{r_2} \cos \theta_2 - 1}{1 + \left(\frac{c}{r_2}\right)^2 - 2 \frac{c}{r_2} \cos \theta_2}$$

Differentiating again,

$$\alpha_3 - (\omega_2)^2 \frac{\frac{c}{r_2} \sin \theta_2 \left(1 - \left(\frac{c}{r_2}\right)^2\right)}{\left(1 + \left(\frac{c}{r_2}\right)^2 - 2 \frac{c}{r_2} \cos \theta_2\right)^2}$$

5.2. Design of Lever

$$T_1 = M_1 * a = M_2 * b = T_2$$

The Mechanical Advantage (MA) of the lever is the ratio of output force to input force,

$$MA = \frac{M_2}{M_1} = \frac{a}{b}$$

5.3. Design Calculation for Sheet Feed

Length of the sheet to be feed can be adjusted by changing the diameter of the roller. The sheet feed length = (circumference of the roller)/no. of slots in Geneva wheel.

$$L = (2 * \pi * R) / Z$$

Where Z is the number of slots in the Geneva wheel.
R is the radius of the roller,
L is the length of the sheet to be feed.

Therefore, Sheet Feed length, $L = (2 * \pi * 60) / 4$

$$= 94.24 \text{ cm}$$

5.4. Cycle time and Dwell time

The wheel moves through 90o for a complete driver cycle. Therefore, one full wheel cycle is equivalent to four-fold driver cycle time (4). The Geneva wheel's dwell time is the sheet cutting time. Calculation of the sheet's operator cycle time and cutting time using equations (1) to (2).The sheet Cutting time, Cycle time, Dwell time were verified using a stopwatch.

$$T_c = \frac{1}{N} \tag{1}$$

Where T_c = cycle time, min

N = rotational speed of driver, rev/min.

$$T_s = \frac{180+2\beta}{360N} \tag{2}$$

Where T_s = Dwell time, min

2β = Angle between adjacent slots of the Geneva wheel, Degrees

5.5. Application of Geneva mechanism in Industry

In the induction module, Geneva processes are commonly used. We use this cam within pharmaceutical machines in the industry. This cam has a very specific job. As shown in the figures below, there are three specific forms of uses of Geneva motion in our industry.

5.5.1. External Geneva Mechanism

The driver pin mates throughout the ride with the driven wheel slots.

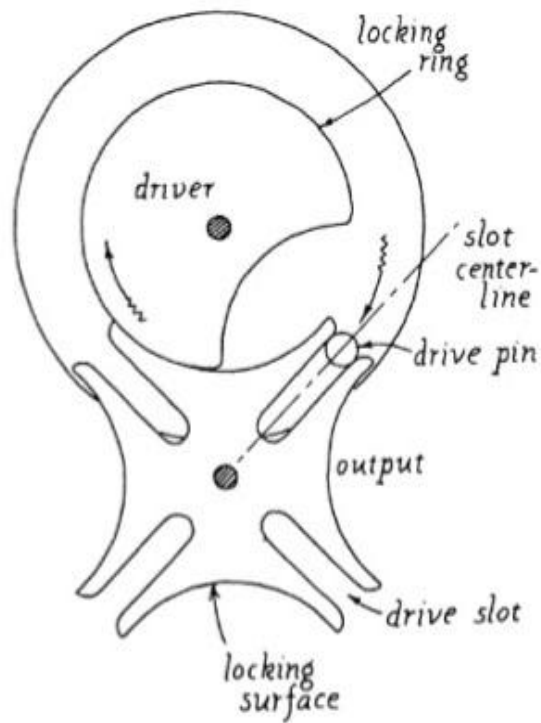

Fig. 14: External Geneva Mechanism

It is most commonly used in industrial purpose and also it is easy to design and manufacture. In stability point of view this Mechanism is more stable and efficient.

5.5.2. Internal Geneva Mechanism

The time of dwelling is 180°.

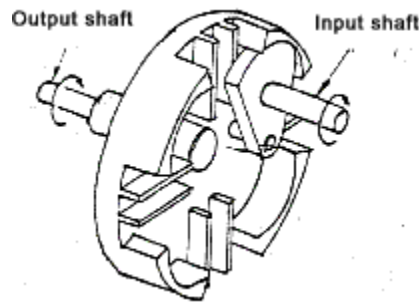

Fig. 15:Internal Geneva Mechanism

5.5.3. Spherical Geneva Mechanism

It is very rarely used for industrial purpose, because its manufacturing is difficult and also it is complex in shape. And at stability point of view it has more wear and tear, therefore it is less stable.

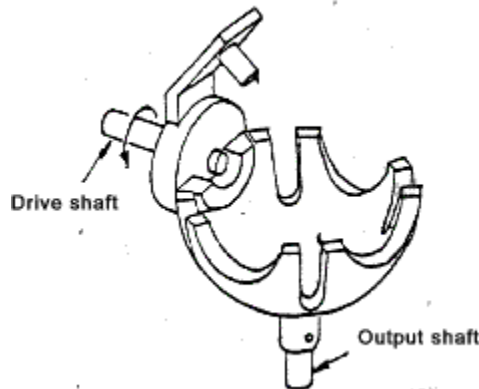

Fig. 16: Spherical Geneva Mechanism

Cost Estimation

Table 3: Cost estimation

S.No.	Part and Description	Cost
-------	----------------------	------

1	Geneva wheel	1700
2	Sprockets	900
3	Roller chain	900
4	Sheet cutter	380
5	Sheet roller	440
6	Coil spring	130
7	Shaft	240
8	Frame, base and other materials	3100
9	Service charge	2200
10	Electric Motor	1475
11	TOTAL	11465

6.1 Future Scope of Project

- i. Operation is smooth and with less effort, we can achieve more efficiency in this process.
- ii. With the launch of the Geneva Wheel Drive Transmission, simple construction.
- iii. The research is immediately served.
- iv. Low cost Automation.
- v. Less Maintenance.

6.2 Advantages of Geneva Mechanism

- i. No need for marking the sheet.
- ii. Cutting the sheet is easy.
- iii. No noise pollution.

- iv. Compact in size.
- v. Can able to cut 5 sheets at a time.
- vi. Can change the machine elements easily

7. Conclusion

In order to rotate the spindle, this machine must resolve all demerits by compact size, lower cost, no need for skilled people and much less electrical input. The development procedure is carried out to produce this machine's Geneva wheel and other components. Changing the roller diameter changes the sheet feed. Thus the sheet cutting in accurate dimensions without marking the sheet is achieved by getting the intermittent motion by Geneva mechanism. This intermittent motion is used to feed the sheet between the cutting periods of the crank and lever mechanism. The crank and lever mechanism helps in cutting the sheet. This mechanism actuates the cutter when the Geneva is in disengaged position. The Experimental tests on mechanism was performed many times for each selected speed. And appropriate size and thickness of sheet were used for cutting purpose. Thus the required intermittent motion is achieved. Hence the sheet is feed and cut by crank and lever mechanism. The main objective of the mechanism is to reduce the timing for sheet cutting and to neglect the time to mark the sheet, this goal is achieved using the Geneva mechanism in our sheet cutting machine.

References

- [1]. Ferdinand P. Beer and E. Russell Johnston Jr., "*Engineering Mechanics*", McGraw-Hill(2005).
- [2]. <https://www.britannica.com/technology/Geneva-mechanism>, Encyclopedia Britannica.
- [3]. Vijay Kumar U, et al., "*Design and Analysis of Sheet Cutting Machine work on the Geneva Mechanism*", IJARIE, 2(2), 35-43(2016).
- [4]. Han Jiguag Yu Kang, "*Analysis and Synthesis of Geneva Mechanism with Elliptic Crank*", International Journal of Hybrid Information Technology, 8(8), 253-260 (2015).
- [5]. Haraga and Elena Ionita, "*Aspects Theoretical and Practical based on the Finite Element Analysis and Modeling of Geneva Mechanism*", IJASTR, 1(2), 20-40 (2015).

- [6]. Madhoo G, et al., “*Force Analysis of Geneva Wheel and Face Cam Used In Automat*”, International Journal of Engineering Research and Applications, 4(6),73-88(2014).
- [7]. P.Kalisindhur, et al., “*Cutting mechanism by giving feed through Geneva Mechanism*”, IJSET,2(4), 1172-1175 (2015).
- [8]. J.J. Lee, K.F. Huang, “*Geometry analysis and optimal design of Geneva mechanisms with curved slots*”, Journal of Mechanical Engineering Science, Proceedings of the Institution of Mechanical Engineers, Part C 218 (4) 449–4540–45(2004).
- [9]. Sniegowski J. F. and Garcia E. J., “*Surface MicroMachined Gear trains Driven by a On-Chip Electrostatic Microengine*” vol. 48, pp. 203-214, 1995.
- [10]. Sniegowski J. F. et al, “*Monolithic geared-mechanisms driven by a polysilicon surface-micromachined on-chip electrostatic microengine*”, Solid-State Sensor and Actuator Workshop, Hilton Head Is., SC, pp. 178-182, (1996).
- [11]. Maarten P. de Boer et al, “*A hinged-pad test structure for sliding friction measurement in micromachining*”, SPIE Proceedings, v. 3512, Materials and Device Characterization in Micromachining, pp. 241250, (1998).

Appendix

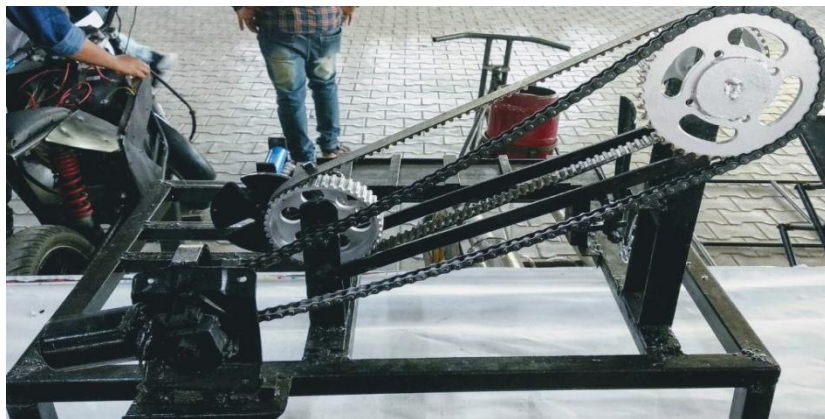

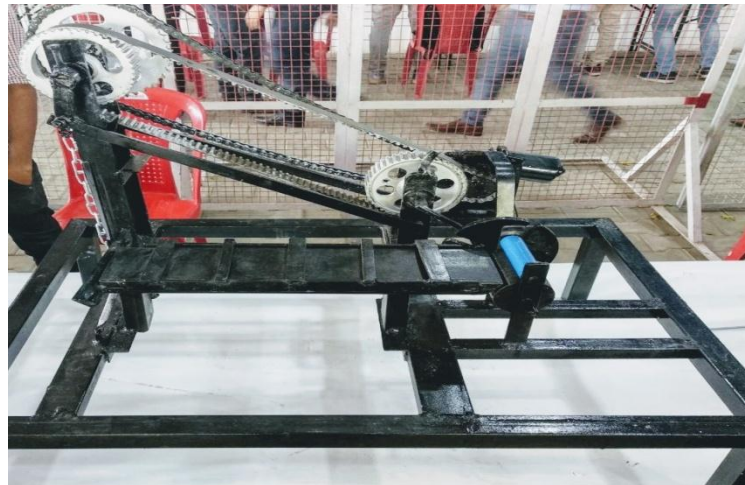

Fig: Pictures of fabrication of machine