

# Mqtt Protocol Based Smart Irrigation: A Cost Effective Method

Hemlata Dalmia, Sanjana Mathew and Subrahmanyam Sayila

Department of ECE, Sreyas Institute of Engineering and technology, Hyderabad

## ABSTRACT

*Agriculture is the main occupation in India. The inflation rate directly gets affected by the impact on agriculture and on the system involved in it. In agriculture also, the very beguiling issue is Irrigation in which a farmer frequently must check the water level on the farm and has to pump off and on irrespective of night time. Such issue can be resolved by replacing the old methods by new ones. This paper introduces a smart irrigation by designing a very flexible water pump using a soil moisture sensor and MQTT protocol along with Node MCU which is a microcontroller unit having wifi facility. MQTT protocol used to receive and transmit message from sensors which will provide the status of soil. And Node MCU -12E accordingly operate the water pump over web page or moile phones. MQTT protocol is very cost effective and simple technique applied to provide a smart irrigation.*

*Keywords: component; formatting; sensors; (key words)*

## I. INTRODUCTION

As an immediate effect of worldwide environmental change, oil value climbs furthermore, budgetary hypothesis, food shortage has got to be one of today's most basic issues that people need to confront truly. Since the conventional farming is profoundly climate dependent, there lies an immediate urge to create and sustain an environment for round the year production using the scientific technology. Ahmed et al. (2016) describes continuous advancements in wireless domain and the development in the Internet of Things (IoT) have empowered the physical world to imperceptibly interlace with sensors, actuators and other computational components while continuously ensuring network connectivity [1]. The persistently associated physical world with computational components shapes a savvy situation for a smarter environment. Thus providing an environment that aims and improve the capacities of its inhabitants in executing their undertakings. It explains that since IOT contains many devices and correspondence concentrated design and so as to detect and control their surroundings, applications in the Internet of Things are required to coordinate and deal with a substantial number of heterogeneous gadgets, which generally range as straightforward sensors and actuators. As of late, however, devices that essentially sense the environment and activate elements are also obliged to execute in situations with constrained processing capacity, limited memory and little bandwidth abilities [4]. Vishwanath et al. (2016) explains that there is a need to standardize protocols conventions to empower all gadgets to speak with each other with different components along with various essential features like interoperability, latency, security, computation ability, quality of service and packet los [2]. Vogler et al. (2015) presents an introduction to the protocol Message Query Telemetry Transport (MQTT)The various levels of Quality of Service (QOS) is discussed and categorized into 3 types – (QoS = 0), (Qos = 1) and (Qos = 2) and described as message sent only once, at least once and exactly once respectively. Also a solution was proposed to make that guaranteed no information loss using the intermediate buffering technique [3]. However the drawback was memory leaks when the buffer capacity was full and overloaded. Kim et al. (2015) does an analysis on the various research oriented concerns with the evolution of the Internet of Things (IOT) [8] .

## II. LITERATURE REVIEW

Researchers	Year	Remote Monitoring technique used	Applications	Comments
Chen Peijiang, Jiang Xuehua	2008	GSM -SMS in PDU mode, Remote Mobile	Remote MS based on MSP430F149 MCU,	System costly due to usage of $\geq 2$ GSM modules

		Station , Central monitoring system, Use GSM module Siemens TC35	Central monitoring system based on PC with database	Facility to store and print data at CMS. Low Power consumption at remote MS
ScanailC.N, Ahearne B., Lyons G M	2006	GSM-SMS, Portable unit & Remote Server use GSM module Falcom A2D-1	Accelerometer-based portable unit using ADuC812S $\mu$ C for mobility measurement of elderly person	appropriate medical expertise provided when mobility levels decrease below threshold level
Baris Yuksekkay A. Kayalar M. Bilgehan Alper	2006	GSM, Internet & Voice between user server. RF lighting ASK between home appliances. Home using server provided with GSM module	Home automation with ventilation camera temp., motion nodes using PIC16f876. Usercell phone application in JavaME	Versatile Home automation Control application developed with diverse comm
PengLiu, Goujun Dai, Tingting Fu	2007	Internet using Web services based email extension for remote monitoring	Remote meter reading, Home automation	Technologies to provide reliability but is costly in implementation. Non-real time but free email services
Flammini, Mario A, li, Sisin ni D, Taroni A	2007	GSM with server centre and DECT,( between acquisition sensors)	Acquisition system based on PIC18F452, Transmitter module on ARM S3F441FX	Low power scheme developed for environmental monitoring using temp. , humidity & CO sensors
Chia-Shen Tsai Bo-Fushe	2008	Bluetooth between appliance and mobile GPRS/WLAN between mobile and data server (Internet and Intranet)	C2.1 for home appliances & Dopod699 PDA as mobile device controller(Java ME) remote control of	

**ANALYSIS AND DESIGN**

**Design:** The above diagram shows the system architecture of the project. The smart agriculture based water pump is facilitated with controller of on/off switching and ESP8266 NodeMCU-12E with MQTT protocol. Firstly the microcontroller unit is getting the input from Soil moisture sensor and relays and the output is given using MQTT server, a display unit. The data collected using soil moisture sensor is sent through MQTT server to the users [6]. The whole project can be sectioned into two parts: one is sensor and relay, the second section consists of MQTT protocol – Internet of Things used to display the results achieved. The microcontroller is having wired connections with soil moisture sensors and relays.

**Analysis:** The first aspect of project includes the testing and checking of the soil moisture sensor, relay, and Esp8266 NodeMCU-12E. In the second aspect, the user initially does the primary procedure of MQTT-Thingier.io [7]. At this aspect, the Thingier.io library has to be installed by the user in the microcontroller ARDUINO – IDE. Testing and checking is done using some inbuilt examples. The same can be compiled for testing and correcting the transmitted and received messages between the publisher and subscriber. Whenever the data measured by sensors and sent to Esp8266NodeMCU-12E, the details of soil moisture sensor value and water pump status are visible to the user with the help of the above primary procedure. And the final data can be viewed using the webpage and smart android application.

**III. PROPOSED METHODOLOGY**

India is an agriculture country, whose economical growth depends upon agricultural development. As the half population of India is having main occupation as agriculture, it becomes necessity to give attention to all the activities involved in it. This paper is concentrating on irrigation system in which according to traditional method farmers have to keep on checking the water level in the plough field and turn on and off the pump to water the soil enough. A block diagram drawn in this paper represents the design in which Node MCU ( a microcontroller Esp8266NodeMCU-12E) with soil sensor are used..

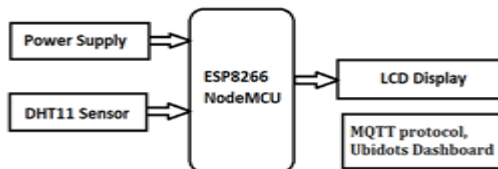

Fig.1: Block diagram of low cost smart irrigation using MQTT protocol

**SCHEMATIC DIAREAM OF MQTT PROTOCOL:**

ESP8266Node MCU has good features to be incorporated in this project. In NodeMCU has a WiFi module which is a self supporting system on chip along with an integrated TCP/IP protocol stack. With the help of this, any microcontroller can utilize or connected to wifi system. ESP8266 is of low cost because it any application can be run and introduced through it and all wifi features can be off loaded using any microprocessor. It has preprogrammed module with AT command, in other words if connected with and Arduino board it will offer complete wifi ability and features.

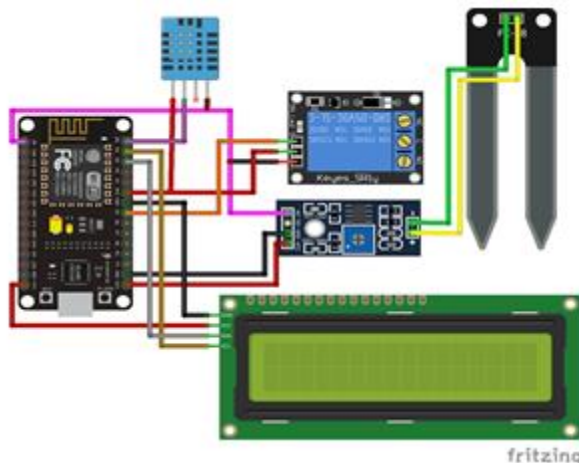

Fig 2: Schematic block diagram of MQTT protocol

Circuit diagram For Monitoring Temperature and Humidity in IOT Cloud

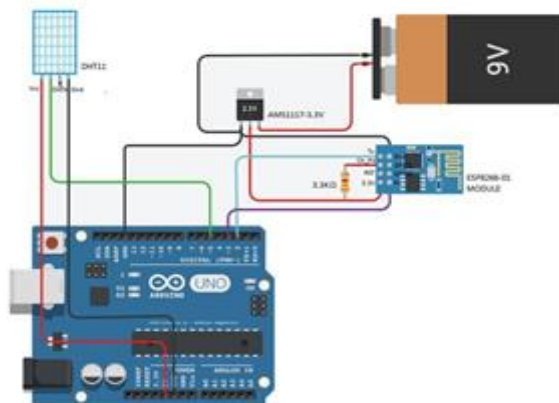

Fig 3: Monitoring Temperature And Humidity In IOT Cloud

The 2nd pin is of DHT11 is a data pin, it can send a temperature and humidity value to the 5th pin of Arduino Uno. 1st and 4th pin of DHT11 is a Vcc and Gnd and 3rd pin is no connection. The Arduino Uno process a temperature and humidity value and send it to a ESP8266 WiFi module. The Tx and Rx pin of ESP8266 is connected to the 2nd (Rx) and 3rd (Tx) of Arduino Uno. Make sure that input voltage of ESP8266 must be 3.3V, not a 5V (otherwise it would damage a device). For that, we are using AMS1117 Voltage regulator circuit. It can regulate a voltage from 9V to 3.3V and will give it to Vcc pin of ESP8266. The Ch\_Pd is a chip enable pin of ESP8266 and should be pull up to 3.3V through 3.3KΩ resistor. For re

The 2nd pin is of DHT11 is a data pin, it can send a temperature and humidity value to the 5th pin of Arduino Uno. 1st and 4th pin of DHT11 is a Vcc and Gnd and 3rd pin is no connection. The Arduino Uno process a temperature and humidity value and send it to a ESP8266 WiFi module. The Tx and Rx pin of ESP8266 is connected to the 2nd (Rx) and 3rd (Tx) of Arduino Uno. Make sure that input voltage of ESP8266 must be 3.3V, not a 5V (otherwise it would damage a device). For that, we are using AMS1117 Voltage regulator circuit. It can regulate a voltage from 9V to 3.3V and will give it to Vcc pin of ESP8266. The Ch\_Pd is a chip enable pin of ESP8266 and should be pull up to 3.3V through 3.3KΩ resistor. For reset the module pull down the RST pin of ESP8266 to Gnd. ESP8266 have 2 GPIO pins GPIO 0 and GPIO 2. set the module pull down the RST pin of ESP8266 to Gnd. ESP8266 have 2 GPIO pins GPIO 0 and GPIO 2.

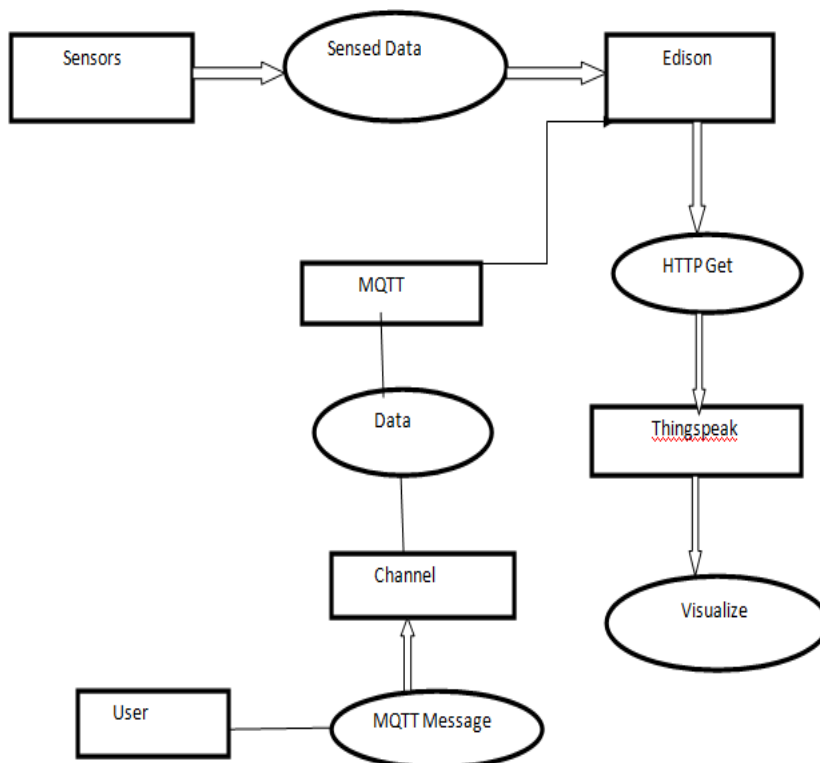

Fig 3: Flow Chart for MQTT Protocol

Thing Speak is an open source platform to store and retrieve a data for Internet of Things application. To use this, you need to register in Thing Speak cloud and then login to your account. After create a new channel with temperature in one field and humidity in another field. Once you created a new channel, it will generate a two API keys, they are READ API keys and WRITE API keys.

**V. RESULT**

Due to very cause of the environmental changes, many factors such as oil rates, budget and food shortage are now basic issues to be concentrated highly.

The smart physical world with all calculative values will picture out the new smart environment for inhabitants to perform their undertakings with good accuracy.



Fig.1: low cost smart irrigation using MQTT protocol



Fig.2: Sensor level measurement

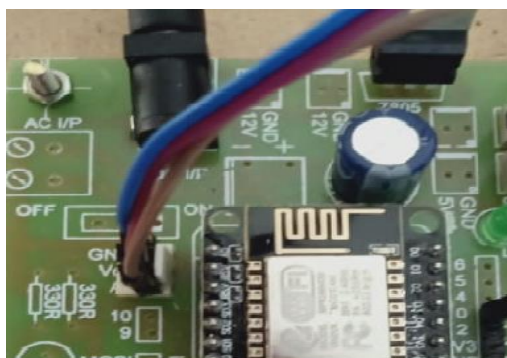

Fig 3: Node MCU connections

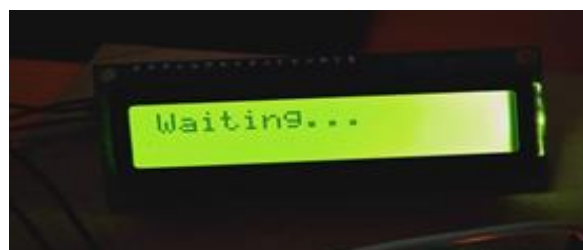

Fig.4: waiting indication



Fig.5: Message sends successfully

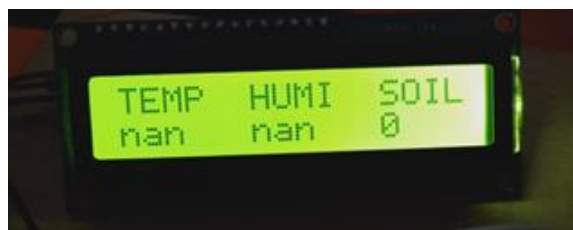

Fig 6: when soil level is zero

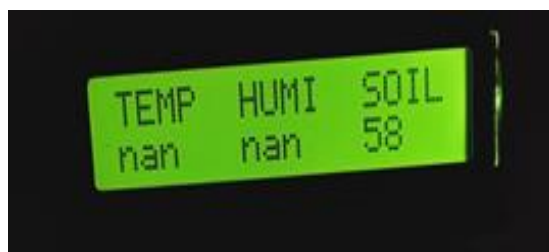

Fig.5: Soil level increases

#### IV. CONCLUSION

Using MQTT protocol, the research was totally concentrating to provide an effective and low cost design with greenhouse affects in agriculture applications.

The merit of the work is that when connected to internet of things, no tunings are required for designers. In place of checking physically while walking in the field, this project is successful in the movement of wheel chair with the help of hands.

#### V. FUTURE SCOPE

In future the same work can be enhanced using multiple raspberry pi for data monitoring and using other sensors like pH sensor and so on for implementation on large agriculture land and for selection of QoS (the Quality of service levels of MQTT protocol). Detailed analysis of MQTT Broker server performance, communication among multiple clients and throughput rates considering different numbers of topics needs to be studied when implementing on large scale environment

#### VI. REFERENCES

- [1] Ahmed, E., I. Yaqoob, A. Gani, M. Imran and M. Guizani, 2016. Internet-of-things-based smart environments: State of the art, taxonomy and open research challenges. *IEEE Wireless Communi.*, 23: 10-16. DOI: 10.1109/MWC.2016.7721736
- [2] Vishwanath, S.K., C. Yen, W. Tushar, W.T. Li and C.K. Wen et al., 2016. System design of the internet of things for residential smart grid. *Proceedings of the IEEE Wireless Communi.*, 23: 90-98. DOI: 10.1109/MWC.2016.7721747
- [3] Vogler, M., J. Schleicher, C. Inzinger and S. Dustdar, 2016. Optimizing Elastic IoT Application Deployments. *IEEE Trans. Services Comput.* DOI: 10.1109/TSC.2016.2617327
- [4] Singh, M., M.A. Rajan, V.L. Shivraj and P. Balamuralidhar, 2015. Secure MQTT for internet of things (IoT). *Proceedings of the Fifth International Conference on Communication Systems and Network Technologies*, April 4-6, IEEE Xplore press, Gwalior, India. DOI: 10.1109/CSNT.2015.16
- [5] Samal, N. and U.C. Pati, 2014. Multi-channel data acquisition and data logging for green house application. *Proceedings of the IEEE Students' Conference on Electrical, Electronics and Computer Science*, March 1-2, IEEE Xplore press, Bhopal, India. DOI: 10.1109/SCEECS.2014.6804507
- [6] Lee, S., H. Kim, D.K. Hong and H. Ju, 2013. Correlation analysis of MQTT loss and delay according to QoS level. *Proceedings of the International Conference on Information Networking*, Jan. 28-30, IEEE Xplore press, Bangkok, Thailand, pp: 714-717. DOI: 10.1109/ICOIN.2013.6496715

- [7] Sandeep Kumar & Hemlata Dalmia, "A Study on Internet of Things Applications and Related Issues", International Journal of Applied and Advanced Scientific Research, Vol. 2, No. 2, pp. 273-277, 2017 with ISSN: 2456-3080
- [8] Kim, S.M., H.S. Choi and W.S. Rhee, 2015. IoT Home Gateway for Auto-Configuration and Management of MQTT devices. Proceedings of the IEEE Conference on Wireless Sensors, Aug. 24-26, IEEE Xplore press, Melaka, Malaysia. DOI: 10.1109/ICWISE.2015.7380346